

Precision High Voltage Current Sense Amplifier

Check for Samples: [LMP8640](#), [LMP8640HV](#)

FEATURES

- Typical Values, $T_A = 25^\circ\text{C}$
- High Common-Mode Voltage Range
 - LMP8640: -2V to 42V
 - LMP8640HV: -2V to 76V
- Supply Voltage Range: 2.7V to 12V
- Gain Options: 20V/V; 50V/V; 100V/V
- Max Gain Error: 0.25%
- Low Offset Voltage: 900 μV
- Input Bias Current: 13 μA
- PSRR: 85 dB
- CMRR (2.1V to 42V): 103 dB
- Temperature Range: -40°C to 125°C
- 6-Pin SOT Package

APPLICATIONS

- High-Side Current Sense
- Vehicle Current Measurement
- Motor Controls
- Battery Monitoring
- Remote Sensing
- Power Management

Typical Application

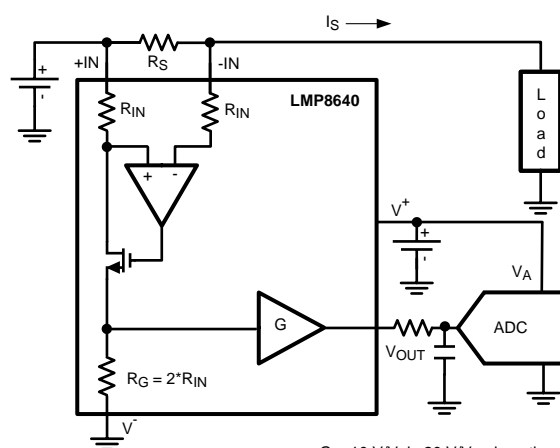

$G = 10 \text{ V/V}$ in 20 V/V gain option
 $G = 25 \text{ V/V}$ in 50 V/V gain option
 $G = 50 \text{ V/V}$ in 100 V/V gain option

DESCRIPTION

The LMP8640 and the LMP8640HV are precision current sense amplifiers that detect small differential voltages across a sense resistor in the presence of high input common mode voltages with a supply voltage range from 2.7V to 12V.

The LMP8640 accepts input signals with common mode voltage range from -2V to 42V, while the LMP8640HV accepts input signal with common mode voltage range from -2V to 76V. The LMP8640 and LMP8640HV have fixed gain for applications that demand accuracy over temperature. The LMP8640 and LMP8640HV come out with three different fixed gains 20V/V, 50V/V, 100V/V ensuring a gain accuracy as low as 0.25%. The output is buffered in order to provide low output impedance. This high side current sense amplifier is ideal for sensing and monitoring currents in DC or battery powered systems, excellent AC and DC specifications over temperature, and keeps errors in the current sense loop to a minimum. The LMP8640 and LMP8640HV are ideal choice for industrial, automotive and consumer applications, and it is available in SOT-6 package.



Please be aware that an important notice concerning availability, standard warranty, and use in critical applications of Texas Instruments semiconductor products and disclaimers thereto appears at the end of this data sheet.

All trademarks are the property of their respective owners.



These devices have limited built-in ESD protection. The leads should be shorted together or the device placed in conductive foam during storage or handling to prevent electrostatic damage to the MOS gates.

Absolute Maximum Ratings ⁽¹⁾⁽²⁾⁽³⁾

ESD Tolerance ⁽⁴⁾	Human Body Model	For input pins +IN, -IN	5000V
		For all other pins	2000V
	Machine Model		200V
	Charge device model		1250V
Supply Voltage ($V_S = V^+ - V^-$)			13.2V
Differential Voltage +IN- (-IN)			6V
Voltage at pins +IN, -IN	LMP8640HV		-6V to 80V
	LMP8640		-6V to 60V
Voltage at V_{OUT} pin			V^- to V^+
Storage Temperature Range			-65°C to 150°C
Junction Temperature ⁽⁵⁾			150°C

- (1) "Absolute Maximum Ratings" indicate limits beyond which damage to the device may occur, including inoperability and degradation of device reliability and/or performance. Functional operation of the device and/or non-degradation at the Absolute Maximum Ratings or other conditions beyond those indicated in the Operating Ratings is not implied. Operating Ratings indicate conditions at which the device is functional and the device should not be operated beyond such conditions.
- (2) For soldering specifications, see product folder at www.ti.com and <http://www.ti.com/lit/SNOA549>.
- (3) If Military/Aerospace specified devices are required, please contact the Texas Instruments Sales Office/Distributors for availability and specifications.
- (4) Human Body Model, applicable std. MIL-STD-883, Method 3015.7. Machine Model, applicable std. JESD22-A115-A (ESD MM std. of JEDEC) Field-Induced Charge-Device Model, applicable std. JESD22-C101-C (ESD FICDM std. of JEDEC).
- (5) The maximum power dissipation must be derated at elevated temperatures and is dictated by $T_{J(MAX)}$, θ_{JA} , and the ambient temperature, T_A . The maximum allowable power dissipation $P_{DMAX} = (T_{J(MAX)} - T_A) / \theta_{JA}$ or the number given in Absolute Maximum Ratings, whichever is lower.

Operating Ratings ⁽¹⁾

Supply Voltage ($V_S = V^+ - V^-$)	2.7V to 12V
Temperature Range ⁽²⁾	-40°C to 125°C
Package Thermal Resistance ⁽²⁾	
SOT-6	96°C/W

- (1) "Absolute Maximum Ratings" indicate limits beyond which damage to the device may occur, including inoperability and degradation of device reliability and/or performance. Functional operation of the device and/or non-degradation at the Absolute Maximum Ratings or other conditions beyond those indicated in the Operating Ratings is not implied. Operating Ratings indicate conditions at which the device is functional and the device should not be operated beyond such conditions.
- (2) The maximum power dissipation must be derated at elevated temperatures and is dictated by $T_{J(MAX)}$, θ_{JA} , and the ambient temperature, T_A . The maximum allowable power dissipation $P_{DMAX} = (T_{J(MAX)} - T_A) / \theta_{JA}$ or the number given in Absolute Maximum Ratings, whichever is lower.

2.7V Electrical Characteristics ⁽¹⁾

Unless otherwise specified, all limits ensured for at $T_A = 25^\circ\text{C}$, $V_S = V^+ - V^-$, $V_{SENSE} = +IN(-IN)$, $V^+ = 2.7\text{V}$, $V^- = 0\text{V}$, $-2\text{V} < V_{CM} < 76\text{V}$, $R_L = 10\text{M}\Omega$. **Boldface** limits apply at the temperature extremes.

Parameter		Test Conditions	Min ⁽²⁾	Typ ⁽³⁾	Max ⁽²⁾	Unit
V_{OS}	Input Offset Voltage	$V_{CM} = 2.1\text{V}$	-900 -1160		900 1160	μV
TCV_{OS}	Input Offset Voltage Drift ⁽⁴⁾ ⁽⁵⁾	$V_{CM} = 2.1\text{V}$			2.6	$\mu\text{V}/^\circ\text{C}$
I_B	Input Bias Current ⁽⁶⁾	$V_{CM} = 2.1\text{V}$		12	20 27	μA
e_{ni}	Input Voltage Noise ⁽⁵⁾	$f > 10\text{ kHz}$		117		$\text{nV}/\sqrt{\text{Hz}}$
Gain A_v	Fixed Gain LMP8640-T LMP8640HV-T			20		V/V
	Fixed Gain LMP8640-F LMP8640HV-F			50		V/V
	Fixed Gain LMP8640-H LMP8640HV-H			100		V/V
	Gain error	$V_{CM} = 2.1\text{V}$	-0.25 -0.51		0.25 0.51	%
	Accuracy over temperature ⁽⁵⁾	-40°C to 125°C , $V_{CM}=2.1\text{V}$			26.2	$\text{ppm}/^\circ\text{C}$
PSRR	Power Supply Rejection Ratio	$V_{CM} = 2.1\text{V}$, $2.7\text{V} < V^+ < 12\text{V}$,	85			dB
CMRR	Common Mode Rejection Ratio	LMP8640HV $2.1\text{V} < V_{CM} < 42\text{V}$ LMP8640 $2.1\text{V} < V_{CM} < 42\text{V}$	103			dB
		LMP8640HV $2.1\text{V} < V_{CM} < 76\text{V}$	95			
		$-2\text{V} < V_{CM} < 2\text{V}$,	60			
BW	Fixed Gain LMP8640-T LMP8640HV-T ⁽⁵⁾	DC $V_{SENSE} = 67.5\text{ mV}$, $C_L = 30\text{ pF}$, $R_L = 1\text{M}\Omega$		950		kHz
	Fixed Gain LMP8640-F LMP8640HV-F ⁽⁵⁾	DC $V_{SENSE} = 27\text{ mV}$, $C_L = 30\text{ pF}$, $R_L = 1\text{M}\Omega$		450		
	Fixed Gain LMP8640-H LMP8640HV-H ⁽⁵⁾	DC $V_{SENSE} = 13.5\text{ mV}$, $C_L = 30\text{ pF}$, $R_L = 1\text{M}\Omega$		230		

- (1) Electrical Table values apply only for factory testing conditions at the temperature indicated. Factory testing conditions result in very limited self-heating of the device such that $T_J = T_A$. No specification of parametric performance is indicated in the electrical tables under conditions of internal self-heating where $T_J > T_A$. Absolute Maximum Ratings indicate junction temperature limits beyond which the device may be permanently degraded, either mechanically or electrically.
- (2) Limits are 100% production tested at 25°C . Limits over the operating temperature range are ensured through correlations using statistical quality control (SQC) method.
- (3) Typical values represent the most likely parametric norm at the time of characterization. Actual typical values may vary over time and will also depend on the application and configuration. The typical values are not tested and are not ensured on shipped production material.
- (4) Offset voltage temperature drift is determined by dividing the change in V_{OS} at the temperature extremes by the total temperature change.
- (5) This parameter is ensured by design and/or characterization and is not tested in production.
- (6) Positive Bias Current corresponds to current flowing into the device.

2.7V Electrical Characteristics ⁽¹⁾ (continued)

Unless otherwise specified, all limits ensured for at $T_A = 25^\circ\text{C}$, $V_S = V^+ - V^-$, $V_{\text{SENSE}} = +\text{IN}(-\text{IN})$, $V^+ = 2.7\text{V}$, $V^- = 0\text{V}$, $-2\text{V} < V_{\text{CM}} < 76\text{V}$, $R_L = 10\text{M}\Omega$. **Boldface** limits apply at the temperature extremes.

Parameter		Test Conditions	Min ⁽²⁾	Typ ⁽³⁾	Max ⁽²⁾	Unit
SR	Slew Rate ⁽⁷⁾ ⁽⁵⁾	$V_{\text{CM}} = 5\text{V}$, $C_L = 30\text{ pF}$, $R_L = 1\text{M}\Omega$, LMP8640-T LMP8640HV-T $V_{\text{SENSE}} = 100\text{mVpp}$, LMP8640-F LMP8640HV-F $V_{\text{SENSE}} = 40\text{mVpp}$, LMP8640-H LMP8640HV-H $V_{\text{SENSE}} = 20\text{mVpp}$,		1.4		V/ μs
R_{IN}	Differential Mode Input Impedance ⁽⁵⁾			5		k Ω
I_S	Supply Current	$V_{\text{CM}} = 2.1\text{V}$		420	600 800	μA
		$V_{\text{CM}} = -2\text{V}$		2000	2500 2750	
V_{OUT}	Maximum Output Voltage	$V_{\text{CM}} = 2.1\text{V}$	2.65			V
	Minimum Output Voltage	LMP8640-T LMP8640HV-T $V_{\text{CM}} = 2.1\text{V}$			18.2	mV
		LMP8640-F LMP8640HV-F $V_{\text{CM}} = 2.1\text{V}$				
LMP8640-H LMP8640HV-H $V_{\text{CM}} = 2.1\text{V}$					80	
C_{LOAD}	Max Output Capacitance Load ⁽⁵⁾			30		pF

(7) The number specified is the average of rising and falling slew rates and measured at 90% to 10%.

5V Electrical Characteristics ⁽¹⁾

Unless otherwise specified, all limits ensured for at $T_A = 25^\circ\text{C}$, $V_S = V^+ - V^-$, $V_{\text{SENSE}} = +\text{IN}(-\text{IN})$, $V^+ = 5\text{V}$, $V^- = 0\text{V}$, $-2\text{V} < V_{\text{CM}} < 76\text{V}$, $R_L = 10\text{M}\Omega$. **Boldface** limits apply at the temperature extremes.

Parameter		Test Conditions	Min ⁽²⁾	Typ ⁽³⁾	Max ⁽²⁾	Unit
V_{OS}	Input Offset Voltage	$V_{\text{CM}} = 2.1\text{V}$	-900 -1160		900 1160	μV
TCV_{OS}	Input Offset Voltage Drift ⁽⁴⁾ ⁽⁵⁾	$V_{\text{CM}} = 2.1\text{V}$			2.6	$\mu\text{V}/^\circ\text{C}$
I_B	Input Bias Current ⁽⁶⁾	$V_{\text{CM}} = 2.1\text{V}$		13	21 28	μA
e_{ni}	Input Voltage Noise ⁽⁵⁾	$f > 10\text{ kHz}$		117		nV/ $\sqrt{\text{Hz}}$
Gain A_V	Fixed Gain LMP8640-T LMP8640HV-T			20		V/V
	Fixed Gain LMP8640-F LMP8640HV-F			50		V/V
	Fixed Gain LMP8640-H LMP8640HV-H			100		V/V
	Gain error	$V_{\text{CM}} = 2.1\text{V}$	-0.25 -0.51		0.25 0.51	%
	Accuracy over temperature ⁽⁵⁾	-40°C to 125°C , $V_{\text{CM}} = 2.1\text{V}$			26.2	ppm/ $^\circ\text{C}$
PSRR	Power Supply Rejection Ratio	$V_{\text{CM}} = 2.1\text{V}$, $2.7\text{V} < V^+ < 12\text{V}$,		85		dB

- (1) Electrical Table values apply only for factory testing conditions at the temperature indicated. Factory testing conditions result in very limited self-heating of the device such that $T_J = T_A$. No specification of parametric performance is indicated in the electrical tables under conditions of internal self-heating where $T_J > T_A$. Absolute Maximum Ratings indicate junction temperature limits beyond which the device may be permanently degraded, either mechanically or electrically.
- (2) Limits are 100% production tested at 25°C . Limits over the operating temperature range are ensured through correlations using statistical quality control (SQC) method.
- (3) Typical values represent the most likely parametric norm at the time of characterization. Actual typical values may vary over time and will also depend on the application and configuration. The typical values are not tested and are not ensured on shipped production material.
- (4) Offset voltage temperature drift is determined by dividing the change in V_{OS} at the temperature extremes by the total temperature change.
- (5) This parameter is ensured by design and/or characterization and is not tested in production.
- (6) Positive Bias Current corresponds to current flowing into the device.

5V Electrical Characteristics ⁽¹⁾ (continued)

Unless otherwise specified, all limits ensured for at $T_A = 25^\circ\text{C}$, $V_S = V^+ - V^-$, $V_{\text{SENSE}} = +\text{IN} - (-\text{IN})$, $V^+ = 5\text{V}$, $V^- = 0\text{V}$, $-2\text{V} < V_{\text{CM}} < 76\text{V}$, $R_L = 10\text{M}\Omega$. **Boldface** limits apply at the temperature extremes.

Parameter		Test Conditions	Min ⁽²⁾	Typ ⁽³⁾	Max ⁽²⁾	Unit
CMRR	Common Mode Rejection Ratio	LMP8640HV 2.1V < $V_{\text{CM}} < 42\text{V}$ LMP8640 2.1V < $V_{\text{CM}} < 42\text{V}$	103			dB
		LMP8640HV 2.1V < $V_{\text{CM}} < 76\text{V}$	95			
		$-2\text{V} < V_{\text{CM}} < 2\text{V}$,	60			
BW	Fixed Gain LMP8640-T LMP8640HV-T ⁽⁵⁾	DC $V_{\text{SENSE}} = 67.5\text{ mV}$, $C_L = 30\text{ pF}$, $R_L = 1\text{M}\Omega$		950		kHz
	Fixed Gain LMP8640-F LMP8640HV-F ⁽⁵⁾	DC $V_{\text{SENSE}} = 27\text{ mV}$, $C_L = 30\text{ pF}$, $R_L = 1\text{M}\Omega$		450		
	Fixed Gain LMP8640-H LMP8640HV-H ⁽⁵⁾	DC $V_{\text{SENSE}} = 13.5\text{ mV}$, $C_L = 30\text{ pF}$, $R_L = 1\text{M}\Omega$		230		
SR	Slew Rate ^{(7) (5)}	$V_{\text{CM}} = 5\text{V}$, $C_L = 30\text{ pF}$, $R_L = 1\text{M}\Omega$, LMP8640-T LMP8640HV-T $V_{\text{SENSE}} = 200\text{mVpp}$, LMP8640-F LMP8640HV-F $V_{\text{SENSE}} = 80\text{mVpp}$, LMP8640-H LMP8640HV-H $V_{\text{SENSE}} = 40\text{mVpp}$,		1.6		V/ μs
R_{IN}	Differential Mode Input Impedance ⁽⁵⁾			5		k Ω
I_S	Supply Current	$V_{\text{CM}} = 2.1\text{V}$		500	722 922	μA
		$V_{\text{CM}} = -2\text{V}$		2050	2500 2750	
V_{OUT}	Maximum Output Voltage	$V_{\text{CM}} = 2.1\text{V}$	4.95			V
	Minimum Output Voltage	LMP8640-T LMP8640HV-T $V_{\text{CM}} = 2.1\text{V}$			18.2	mV
		LMP8640-F LMP8640HV-F $V_{\text{CM}} = 2.1\text{V}$				
LMP8640-H LMP8640HV-H $V_{\text{CM}} = 2.1\text{V}$					80	
C_{LOAD}	Max Output Capacitance Load ⁽⁵⁾			30		pF

(7) The number specified is the average of rising and falling slew rates and measured at 90% to 10%.

12V Electrical Characteristics ⁽¹⁾

Unless otherwise specified, all limits ensured for at $T_A = 25^\circ\text{C}$, $V_S = V^+ - V^-$, $V_{\text{SENSE}} = +\text{IN} - (-\text{IN})$, $V^+ = 12\text{V}$, $V^- = 0\text{V}$, $-2\text{V} < V_{\text{CM}} < 76\text{V}$, $R_L = 10\text{M}\Omega$. **Boldface** limits apply at the temperature extremes.

Parameter		Test Conditions	Min ⁽²⁾	Typ ⁽³⁾	Max ⁽²⁾	Unit
V_{OS}	Input Offset Voltage	$V_{\text{CM}} = 2.1\text{V}$	-900 -1160		900 1160	μV
TCV_{OS}	Input Offset Voltage Drift ^{(4) (5)}	$V_{\text{CM}} = 2.1\text{V}$			2.6	$\mu\text{V}/^\circ\text{C}$
I_B	Input Bias Current ⁽⁶⁾	$V_{\text{CM}} = 2.1\text{V}$		13	22 28	μA
e_{ni}	Input Voltage Noise ⁽⁵⁾	$f > 10\text{ kHz}$		117		$\text{nV}/\sqrt{\text{Hz}}$

- (1) Electrical Table values apply only for factory testing conditions at the temperature indicated. Factory testing conditions result in very limited self-heating of the device such that $T_J = T_A$. No specification of parametric performance is indicated in the electrical tables under conditions of internal self-heating where $T_J > T_A$. Absolute Maximum Ratings indicate junction temperature limits beyond which the device may be permanently degraded, either mechanically or electrically.
- (2) Limits are 100% production tested at 25°C . Limits over the operating temperature range are ensured through correlations using statistical quality control (SQC) method.
- (3) Typical values represent the most likely parametric norm at the time of characterization. Actual typical values may vary over time and will also depend on the application and configuration. The typical values are not tested and are not ensured on shipped production material.
- (4) Offset voltage temperature drift is determined by dividing the change in V_{OS} at the temperature extremes by the total temperature change.
- (5) This parameter is ensured by design and/or characterization and is not tested in production.
- (6) Positive Bias Current corresponds to current flowing into the device.

12V Electrical Characteristics⁽¹⁾ (continued)

Unless otherwise specified, all limits ensured for at $T_A = 25^\circ\text{C}$, $V_S = V^+ - V^-$, $V_{\text{SENSE}} = +\text{IN} - (-\text{IN})$, $V^+ = 12\text{V}$, $V^- = 0\text{V}$, $-2\text{V} < V_{\text{CM}} < 76\text{V}$, $R_L = 10\text{M}\Omega$. **Boldface** limits apply at the temperature extremes.

Parameter		Test Conditions	Min ⁽²⁾	Typ ⁽³⁾	Max ⁽²⁾	Unit
Gain A_V	Fixed Gain LMP8640-T LMP8640HV-T			20		V/V
	Fixed Gain LMP8640-F LMP8640HV-F			50		V/V
	Fixed Gain LMP8640-H LMP8640HV-H			100		V/V
	Gain error	$V_{\text{CM}} = 2.1\text{V}$	-0.25 -0.51		0.25 0.51	%
	Accuracy over temperature ⁽⁵⁾	-40°C to 125°C , $V_{\text{CM}} = 2.1\text{V}$			26.2	ppm/ $^\circ\text{C}$
PSRR	Power Supply Rejection Ratio	$V_{\text{CM}} = 2.1\text{V}$, $2.7\text{V} < V^+ < 12\text{V}$,	85			dB
CMRR	Common Mode Rejection Ratio	LMP8640HV $2.1\text{V} < V_{\text{CM}} < 42\text{V}$ LMP8640 $2.1\text{V} < V_{\text{CM}} < 42\text{V}$	103			dB
		LMP8640HV $2.1\text{V} < V_{\text{CM}} < 76\text{V}$	95			
		$-2\text{V} < V_{\text{CM}} < 2\text{V}$,	60			
BW	Fixed Gain LMP8640-T LMP8640HV-T ⁽⁵⁾	DC $V_{\text{SENSE}} = 67.5\text{ mV}$, $C_L = 30\text{ pF}$, $R_L = 1\text{M}\Omega$		950		kHz
	Fixed Gain LMP8640-F LMP8640HV-F ⁽⁵⁾	DC $V_{\text{SENSE}} = 27\text{ mV}$, $C_L = 30\text{ pF}$, $R_L = 1\text{M}\Omega$		450		
	Fixed Gain LMP8640-H LMP8640HV-H ⁽⁵⁾	DC $V_{\text{SENSE}} = 13.5\text{ mV}$, $C_L = 30\text{ pF}$, $R_L = 1\text{M}\Omega$		230		
SR	Slew Rate ⁽⁷⁾ ⁽⁵⁾	$V_{\text{CM}} = 5\text{V}$, $C_L = 30\text{ pF}$, $R_L = 1\text{M}\Omega$, LMP8640-T LMP8640HV-T $V_{\text{SENSE}} = 500\text{mVpp}$, LMP8640-F LMP8640HV-F $V_{\text{SENSE}} = 200\text{mVpp}$, LMP8640-H LMP8640HV-H $V_{\text{SENSE}} = 100\text{mVpp}$,		1.8		V/ μs
R_{IN}	Differential Mode Input Impedance ⁽⁵⁾			5		k Ω
I_S	Supply Current	$V_{\text{CM}} = 2.1\text{V}$		720	1050 1250	μA
		$V_{\text{CM}} = -2\text{V}$		2300	2800 3000	
V_{OUT}	Maximum Output Voltage	$V_{\text{CM}} = 2.1\text{V}$	11.85			V
	Minimum Output Voltage	LMP8640-T LMP8640HV-T $V_{\text{CM}} = 2.1\text{V}$			18.2	mV
		LMP8640-F LMP8640HV-F $V_{\text{CM}} = 2.1\text{V}$			40	
		LMP8640-H LMP8640HV-H $V_{\text{CM}} = 2.1\text{V}$			80	
C_{LOAD}	Max Output Capacitance Load ⁽⁸⁾			30		pF

(7) The number specified is the average of rising and falling slew rates and measured at 90% to 10%.

(8) This parameter is ensured by design and/or characterization and is not tested in production.

DEVICE INFORMATION

Block Diagram

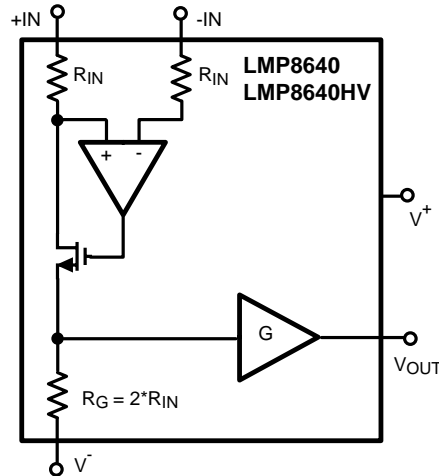

Connection Diagram

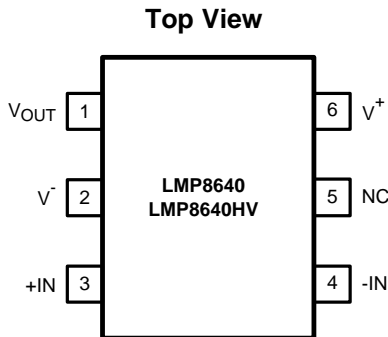

Figure 1. 6-Pin SOT Package
see package number DDC0006A

Table 1. Pin Descriptions

Pin	Name	Description
1	V _{OUT}	Single Ended Output
2	V ⁻	Negative Supply Voltage
3	+IN	Positive Input
4	-IN	Negative Input
5	NC	Not Connected
6	V ⁺	Positive Supply Voltage

Typical Performance Characteristics

Unless otherwise specified: $T_A = 25^\circ\text{C}$, $V_S = V^+ - V^-$, $V_{\text{SENSE}} = +\text{IN} - (-\text{IN})$, $R_L = 10\text{ M}\Omega$.

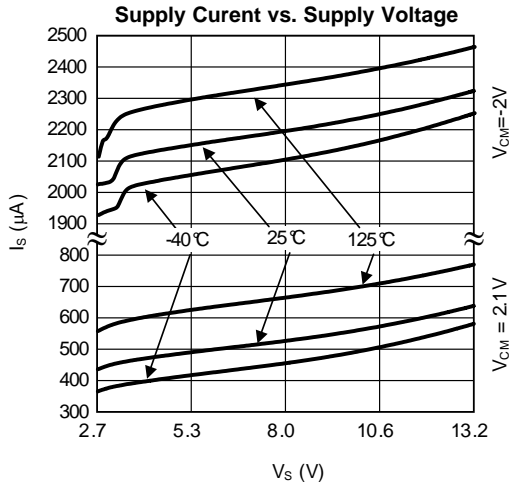

Figure 2.

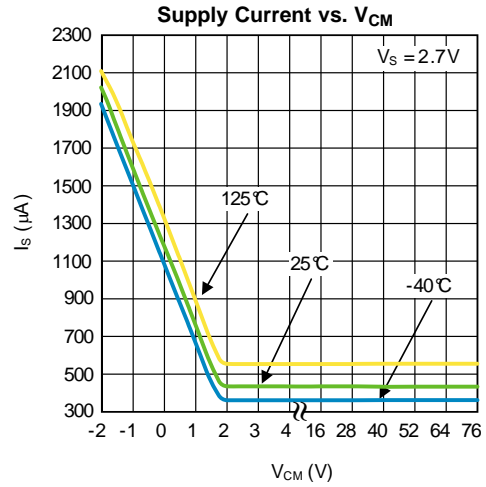

Figure 3.

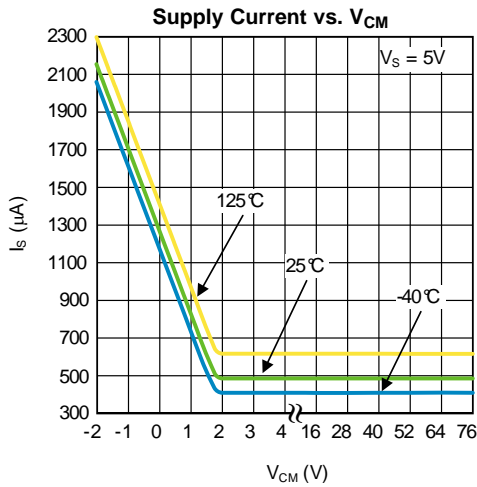

Figure 4.

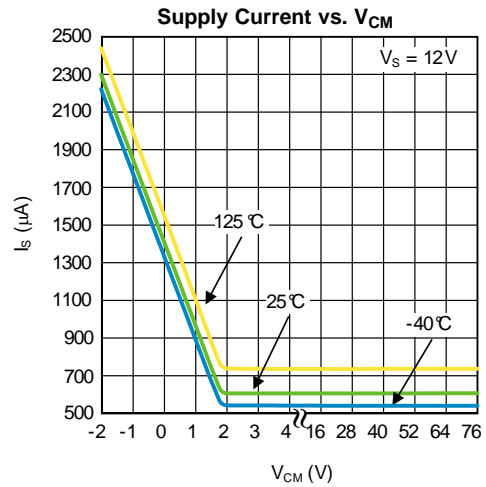

Figure 5.

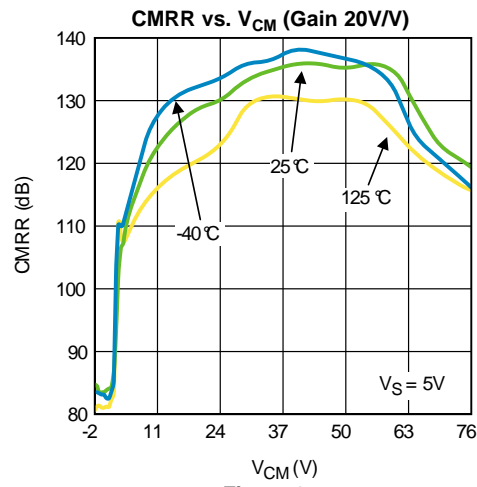

Figure 6.

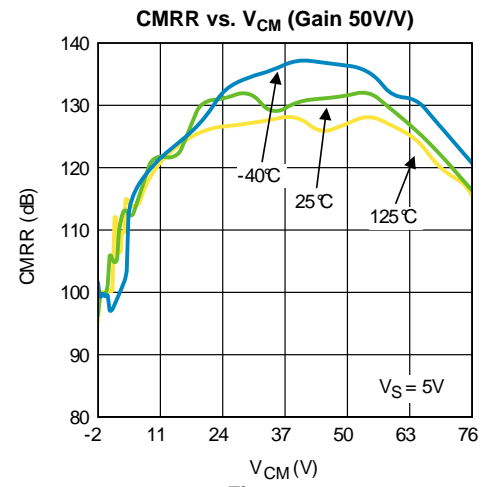

Figure 7.

Typical Performance Characteristics (continued)

Unless otherwise specified: $T_A = 25^\circ\text{C}$, $V_S = V^+ - V^-$, $V_{\text{SENSE}} = +\text{IN} - (-\text{IN})$, $R_L = 10\text{ M}\Omega$.

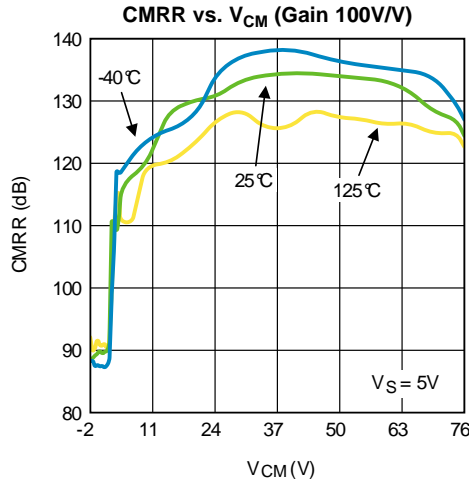

Figure 8.

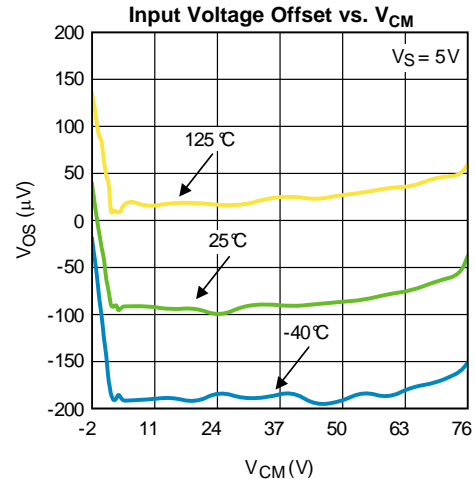

Figure 9.

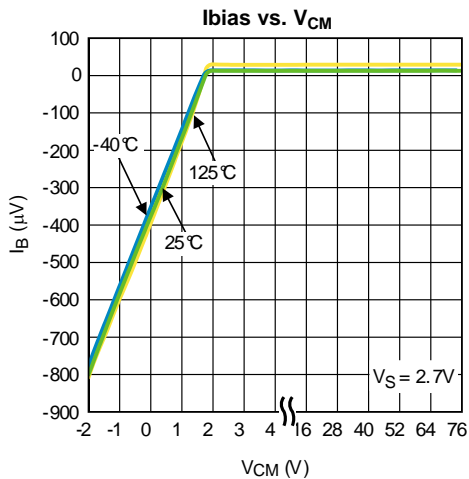

Figure 10.

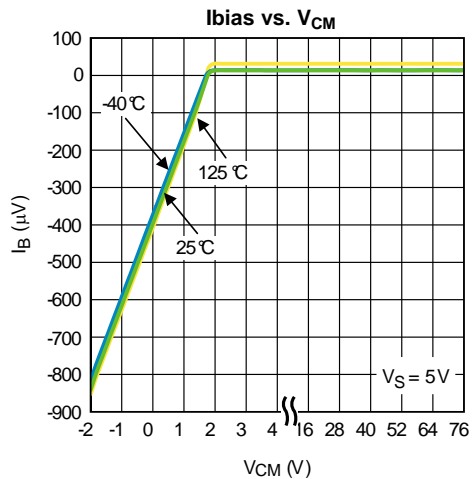

Figure 11.

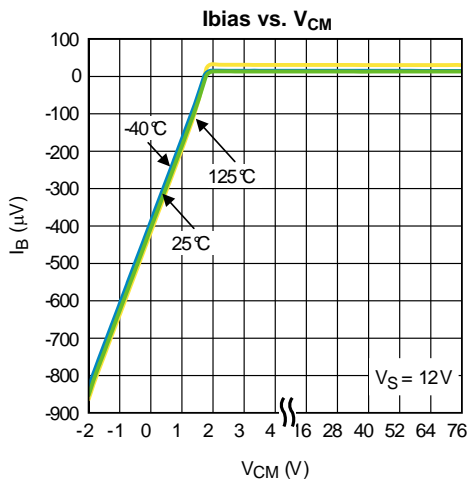

Figure 12.

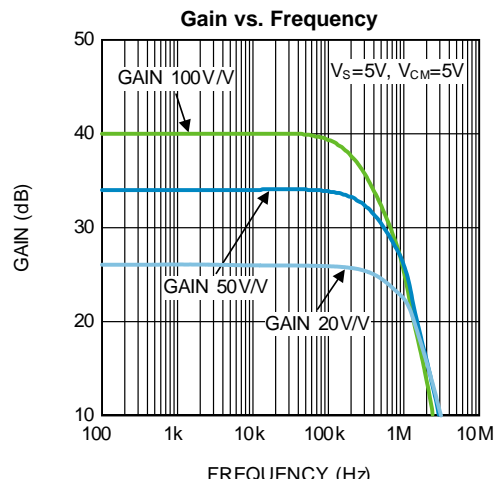

Figure 13.

Typical Performance Characteristics (continued)

Unless otherwise specified: $T_A = 25^\circ\text{C}$, $V_S = V^+ - V^-$, $V_{\text{SENSE}} = +IN - (-IN)$, $R_L = 10\ \text{M}\Omega$.

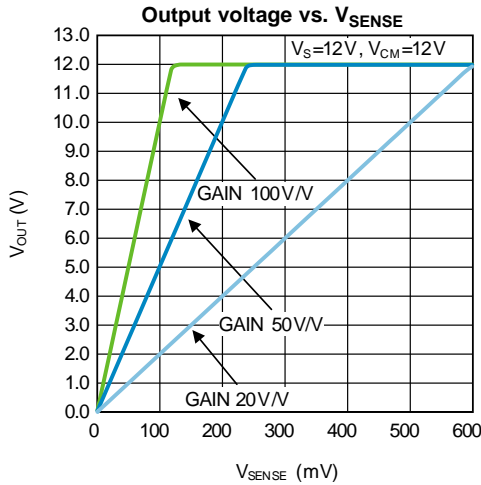

Figure 14.

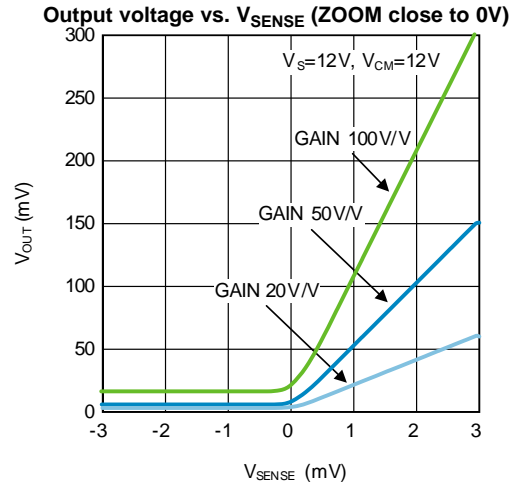

Figure 15.

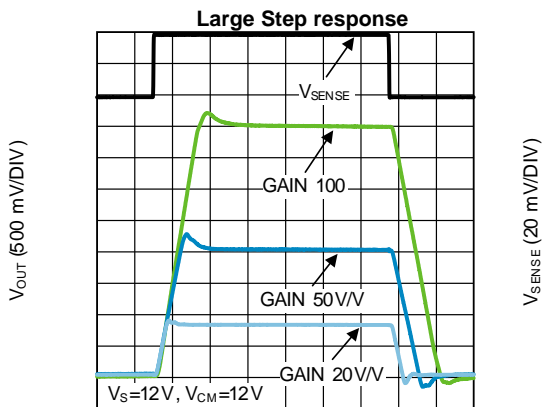

Figure 16.

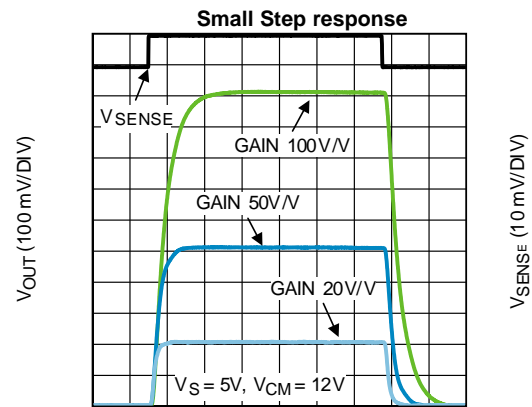

Figure 17.

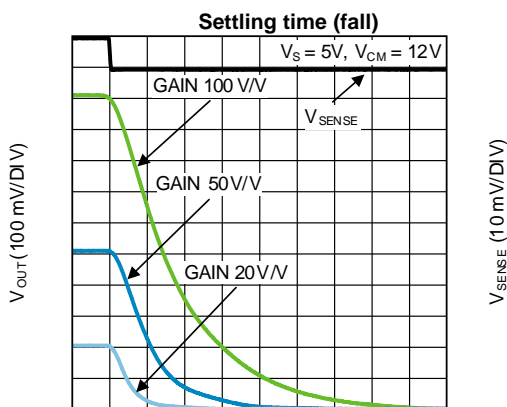

Figure 18.

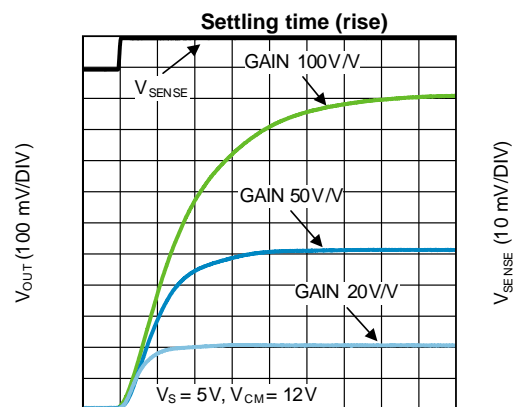

Figure 19.

Typical Performance Characteristics (continued)

Unless otherwise specified: $T_A = 25^\circ\text{C}$, $V_S = V^+ - V^-$, $V_{\text{SENSE}} = +\text{IN} - (-\text{IN})$, $R_L = 10\text{ M}\Omega$.

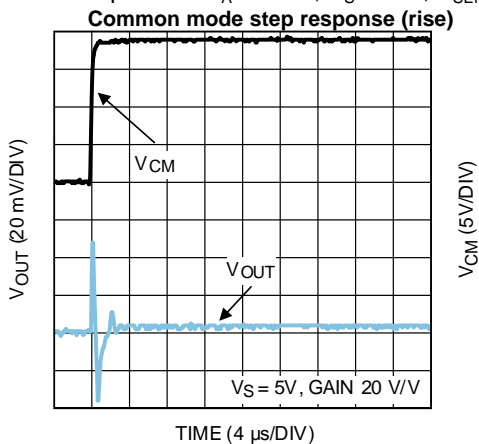

Figure 20.

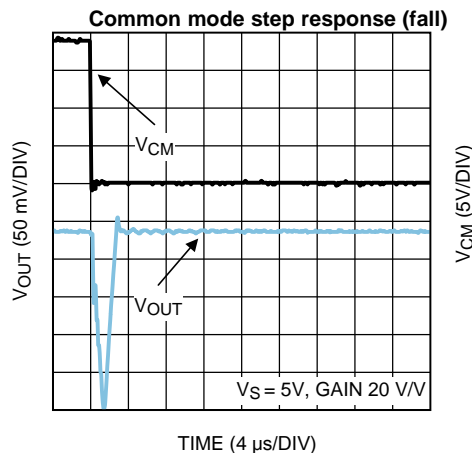

Figure 21.

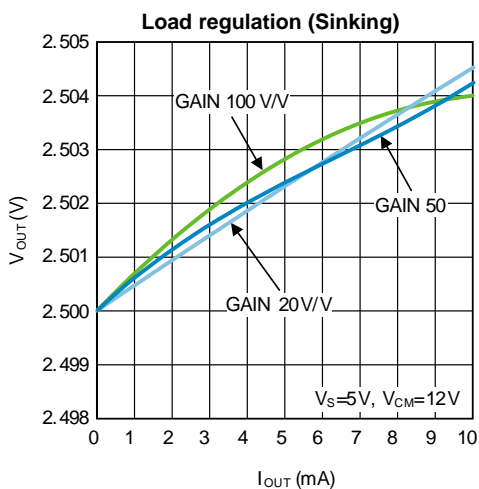

Figure .

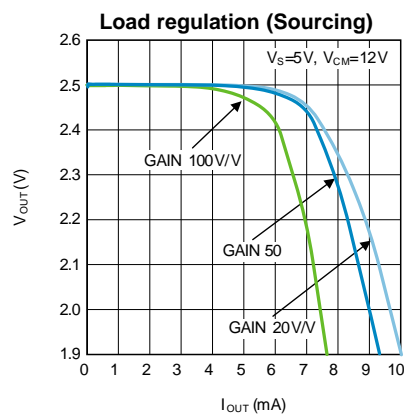

Figure 22.

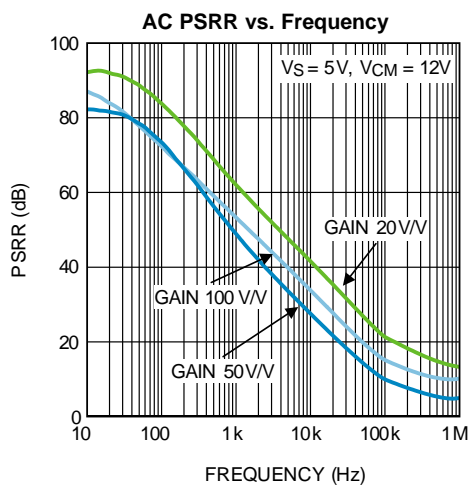

Figure 23.

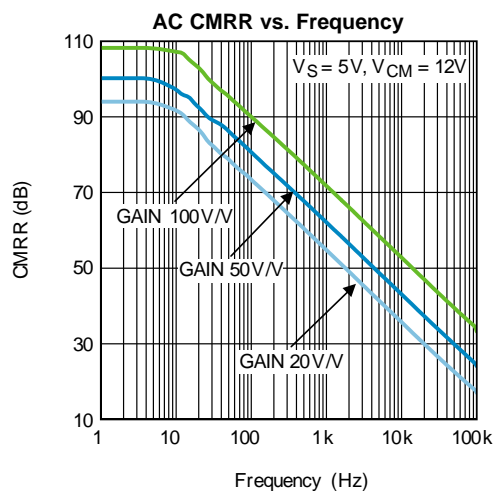

Figure 24.

APPLICATION INFORMATION

GENERAL

The LMP8640 and LMP8640HV are single supply high side current sense amplifiers with a fixed gain of 20V/V, 50V/V, 100V/V and a common mode voltage range of -2V to 42V or -2V to 76V depending on the grade.

THEORY OF OPERATION

As seen from the picture below, the current flowing through R_S develops a voltage drop equal to V_{SENSE} across R_S . The high impedance inputs of the amplifier doesn't conduct this current and the high open loop gain of the sense amplifier forces its non-inverting input to the same voltage as the inverting input. In this way the voltage drop across R_{IN} matches V_{SENSE} . A current proportional to I_S according to the following relation:

$$I_G = V_{SENSE}/R_{IN} = R_S * I_S / R_{IN} \quad (1)$$

flows entirely in the internal gain resistor R_G developing a voltage drop equal to

$$V_{RG} = I_G * R_G = (V_{SENSE}/R_{IN}) * R_G = ((R_S * I_S)/R_{IN}) * R_G \quad (2)$$

This voltage is buffered and showed at the output with a very low impedance allowing a very easy interface of the LMP8640 with other ICs (ADC, $\mu C...$).

$$V_{OUT} = 2 * (R_S * I_S) * G, \quad (3)$$

where $G = R_G/R_{IN} = 10V/V, 25V/V, 50V/V$, according to the gain options.

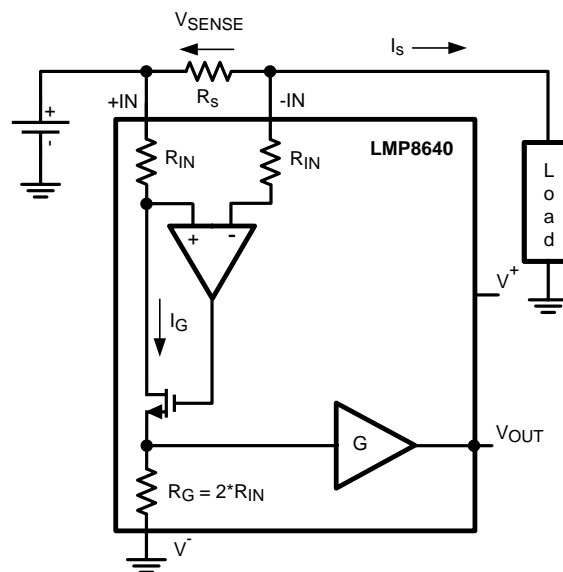

Figure 25. Current Monitor

SELECTION OF THE SHUNT RESISTOR

The value chosen for the shunt resistor, R_S , depends on the application. It plays a big role in a current sensing system and must be chosen with care. The selection of the shunt resistor needs to take in account the small-signal accuracy, the power dissipated and the voltage loss across the shunt itself. In applications where a small current is sensed, a bigger value of R_S is selected to minimize the error in the proportional output voltage. Higher resistor value improves the SNR at the input of the current sense amplifier and hence gives an accurate output. Similarly when high current is sensed, the power losses in R_S can be significant so a smaller value of R_S is suggested. In this condition is required to take in account also the power rating of R_S resistor. The low input offset of the LMP8640 allows the use of small sense resistors to reduce power dissipation still providing a good input dynamic range. The input dynamic range is the ratio expressed in dB between the maximum signal that can be measured and the minimum signal that can be detected, usually the input offset is the principal limiting factor.

DRIVING ADC

The input stage of an Analog to Digital converter can be modeled with a resistor and a capacitance versus ground. So if the voltage source doesn't have a low impedance an error in the amplitude's measurement will occur. In this case a buffer is needed to drive the ADC. The LMP8640 has an internal output buffer able to drive a capacitance load up to 30 pF or the input stage of an ADC. If required an external low pass RC filter can be added at the output of the LMP8640 to reduce the noise and the bandwidth of the current sense.

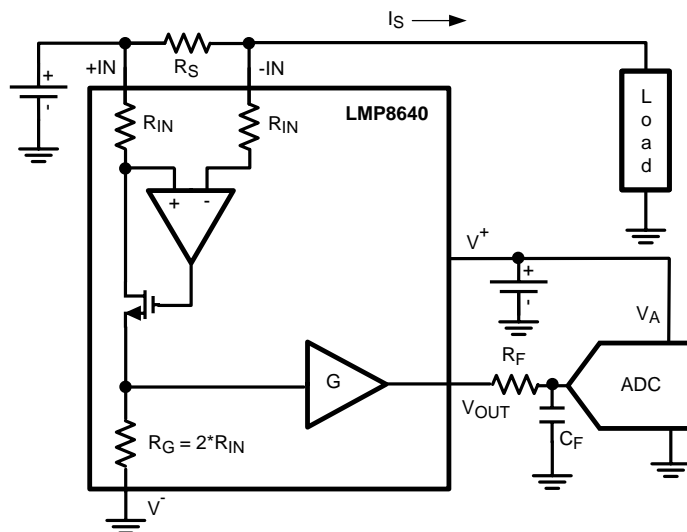

Figure 26. LMP8640 to ADC Interface

DESIGN EXAMPLE

For example in a current monitor application is required to measure the current sunk by a load (peak current 10A) with a resolution of 10mA and 0.5% of accuracy. The 10bit analog to digital converter accepts a max input voltage of 4.1V. Moreover in order to not burn much power on the shunt resistor it needs to be less than 10mΩ. In the table below are summarized the other working condition.

Working Condition	Value	
	Min	Max
Supply Voltage	5V	5.5V
Common mode Voltage	48V	70V
Temperature	0°C	70°C
Signal BW		50kHz

First step – LMP8640 / LMP8640HV selection

The required common mode voltage of the application implies that the right choice is the LMP8640HV (High common mode voltage up to 76V).

Second step – Gain option selection

We can choose between three gain option (20V/V, 50V/V, 100V/V). considering the max input voltage of the ADC (4.1V), the max Sense voltage across the shunt resistor is evaluated according the following formula:

$$V_{SENSE} = (\text{MAX } V_{in \text{ ADC}}) / \text{Gain};$$

hence the max V_{SENSE} will be 205mV, 82mV, 41mV respectively. The shunt resistor are then evaluated considering the maximum monitored current :

$$R_S = (\text{max } V_{SENSE}) / I_{MAX}$$

For each gain option the max shunt resistors are the following : 20.5mΩ, 8.2mΩ, 4.1mΩ respectively.

One of the project constraints requires $R_S < 10\text{m}\Omega$, it means that the $20.5\text{m}\Omega$ will be discarded and hence the 50V/V and 100V/V gain options are still in play.

Third step – Shunt resistor selection

At this point an error budget calculation, considering the calibration of the Gain, Offset, CMRR, and PSRR, helps in the selection of the shunt resistor. In the table below the contribution of each error source is calculated considering the values of the Electrical Characteristics table at 5V supply.

Table 2. Resolution Calculation

ERROR SOURCE	$R_S = 4.1\text{m}\Omega$	$R_S = 8.1\text{m}\Omega$
CMRR calibrated ad mid VCM range	77.9 μV	77.9 μV
PSRR calibrated at 5V	8.9 μV	8.9 μV
Total error (squared sum of contribution)	78 μV	78 μV
Resolution (Total error / R_S)	19.2mA	9.6mA

Table 3. Accuracy Calculation

ERROR SOURCE	$R_S = 4.1\text{m}\Omega$	$R_S = 8.1\text{m}\Omega$
Tc Vos	182 μV	182 μV
Nosie	216 μV	216 μV
Gain drift	75.2 μV	151 μV
Total error (squared sum of contribution)	293 μV	320 μV
Accuracy $100 * (\text{Max_V}_{\text{SENSE}} / \text{Total Error})$	0.7%	0.4%

From the tables above is clear that the $8.2\text{m}\Omega$ shunt resistor allows the respect of the project's constraints. The power burned on the Shunt is 820mW at 10A.

REVISION HISTORY

Changes from Revision D (March 2013) to Revision E	Page
• Changed layout of National Data Sheet to TI format	14

PACKAGING INFORMATION

Orderable Device	Status (1)	Package Type	Package Drawing	Pins	Package Qty	Eco Plan (2)	Lead/Ball Finish	MSL Peak Temp (3)	Op Temp (°C)	Top-Side Markings (4)	Samples
LMP8640HVMK-F/NOPB	ACTIVE	SOT	DDC	6	1000	Green (RoHS & no Sb/Br)	CU NIPDAU	Level-1-260C-UNLIM	-40 to 125	AD6A	Samples
LMP8640HVMK-H/NOPB	ACTIVE	SOT	DDC	6	1000	Green (RoHS & no Sb/Br)	CU NIPDAU	Level-1-260C-UNLIM	-40 to 125	AF6A	Samples
LMP8640HVMK-T/NOPB	ACTIVE	SOT	DDC	6	1000	Green (RoHS & no Sb/Br)	CU NIPDAU	Level-1-260C-UNLIM	-40 to 125	AB6A	Samples
LMP8640HVMKE-F/NOPB	ACTIVE	SOT	DDC	6	250	Green (RoHS & no Sb/Br)	CU NIPDAU	Level-1-260C-UNLIM	-40 to 125	AD6A	Samples
LMP8640HVMKE-H/NOPB	ACTIVE	SOT	DDC	6	250	Green (RoHS & no Sb/Br)	CU NIPDAU	Level-1-260C-UNLIM	-40 to 125	AF6A	Samples
LMP8640HVMKE-T/NOPB	ACTIVE	SOT	DDC	6	250	Green (RoHS & no Sb/Br)	CU NIPDAU	Level-1-260C-UNLIM	-40 to 125	AB6A	Samples
LMP8640HVMKX-F/NOPB	ACTIVE	SOT	DDC	6	3000	Green (RoHS & no Sb/Br)	CU NIPDAU	Level-1-260C-UNLIM	-40 to 125	AD6A	Samples
LMP8640HVMKX-H/NOPB	ACTIVE	SOT	DDC	6	3000	Green (RoHS & no Sb/Br)	CU NIPDAU	Level-1-260C-UNLIM	-40 to 125	AF6A	Samples
LMP8640HVMKX-T/NOPB	ACTIVE	SOT	DDC	6	3000	Green (RoHS & no Sb/Br)	CU NIPDAU	Level-1-260C-UNLIM	-40 to 125	AB6A	Samples
LMP8640MK-F/NOPB	ACTIVE	SOT	DDC	6	1000	Green (RoHS & no Sb/Br)	CU NIPDAU	Level-1-260C-UNLIM	-40 to 125	AC6A	Samples
LMP8640MK-H/NOPB	ACTIVE	SOT	DDC	6	1000	Green (RoHS & no Sb/Br)	CU NIPDAU	Level-1-260C-UNLIM	-40 to 125	AE6A	Samples
LMP8640MK-T/NOPB	ACTIVE	SOT	DDC	6	1000	Green (RoHS & no Sb/Br)	CU NIPDAU	Level-1-260C-UNLIM	-40 to 125	AA6A	Samples
LMP8640MKE-F/NOPB	ACTIVE	SOT	DDC	6	250	Green (RoHS & no Sb/Br)	CU NIPDAU	Level-1-260C-UNLIM	-40 to 125	AC6A	Samples
LMP8640MKE-H/NOPB	ACTIVE	SOT	DDC	6	250	Green (RoHS & no Sb/Br)	CU NIPDAU	Level-1-260C-UNLIM	-40 to 125	AE6A	Samples
LMP8640MKE-T/NOPB	ACTIVE	SOT	DDC	6	250	Green (RoHS & no Sb/Br)	CU NIPDAU	Level-1-260C-UNLIM	-40 to 125	AA6A	Samples
LMP8640MKX-F/NOPB	ACTIVE	SOT	DDC	6	3000	Green (RoHS & no Sb/Br)	CU NIPDAU	Level-1-260C-UNLIM	-40 to 125	AC6A	Samples
LMP8640MKX-H/NOPB	ACTIVE	SOT	DDC	6	3000	Green (RoHS & no Sb/Br)	CU NIPDAU	Level-1-260C-UNLIM	-40 to 125	AE6A	Samples

Orderable Device	Status (1)	Package Type	Package Drawing	Pins	Package Qty	Eco Plan (2)	Lead/Ball Finish	MSL Peak Temp (3)	Op Temp (°C)	Top-Side Markings (4)	Samples
LMP8640MKX-T/NOPB	ACTIVE	SOT	DDC	6	3000	Green (RoHS & no Sb/Br)	CU NIPDAU	Level-1-260C-UNLIM	-40 to 125	AA6A	Samples

(1) The marketing status values are defined as follows:

ACTIVE: Product device recommended for new designs.

LIFEBUY: TI has announced that the device will be discontinued, and a lifetime-buy period is in effect.

NRND: Not recommended for new designs. Device is in production to support existing customers, but TI does not recommend using this part in a new design.

PREVIEW: Device has been announced but is not in production. Samples may or may not be available.

OBSOLETE: TI has discontinued the production of the device.

(2) Eco Plan - The planned eco-friendly classification: Pb-Free (RoHS), Pb-Free (RoHS Exempt), or Green (RoHS & no Sb/Br) - please check <http://www.ti.com/productcontent> for the latest availability information and additional product content details.

TBD: The Pb-Free/Green conversion plan has not been defined.

Pb-Free (RoHS): TI's terms "Lead-Free" or "Pb-Free" mean semiconductor products that are compatible with the current RoHS requirements for all 6 substances, including the requirement that lead not exceed 0.1% by weight in homogeneous materials. Where designed to be soldered at high temperatures, TI Pb-Free products are suitable for use in specified lead-free processes.

Pb-Free (RoHS Exempt): This component has a RoHS exemption for either 1) lead-based flip-chip solder bumps used between the die and package, or 2) lead-based die adhesive used between the die and leadframe. The component is otherwise considered Pb-Free (RoHS compatible) as defined above.

Green (RoHS & no Sb/Br): TI defines "Green" to mean Pb-Free (RoHS compatible), and free of Bromine (Br) and Antimony (Sb) based flame retardants (Br or Sb do not exceed 0.1% by weight in homogeneous material)

(3) MSL, Peak Temp. -- The Moisture Sensitivity Level rating according to the JEDEC industry standard classifications, and peak solder temperature.

(4) Only one of markings shown within the brackets will appear on the physical device.

Important Information and Disclaimer: The information provided on this page represents TI's knowledge and belief as of the date that it is provided. TI bases its knowledge and belief on information provided by third parties, and makes no representation or warranty as to the accuracy of such information. Efforts are underway to better integrate information from third parties. TI has taken and continues to take reasonable steps to provide representative and accurate information but may not have conducted destructive testing or chemical analysis on incoming materials and chemicals. TI and TI suppliers consider certain information to be proprietary, and thus CAS numbers and other limited information may not be available for release.

In no event shall TI's liability arising out of such information exceed the total purchase price of the TI part(s) at issue in this document sold by TI to Customer on an annual basis.

TAPE AND REEL INFORMATION



QUADRANT ASSIGNMENTS FOR PIN 1 ORIENTATION IN TAPE



*All dimensions are nominal

Device	Package Type	Package Drawing	Pins	SPQ	Reel Diameter (mm)	Reel Width W1 (mm)	A0 (mm)	B0 (mm)	K0 (mm)	P1 (mm)	W (mm)	Pin1 Quadrant
LMP8640HVMK-F/NOPB	SOT	DDC	6	1000	178.0	8.4	3.2	3.2	1.4	4.0	8.0	Q3
LMP8640HVMK-H/NOPB	SOT	DDC	6	1000	178.0	8.4	3.2	3.2	1.4	4.0	8.0	Q3
LMP8640HVMK-T/NOPB	SOT	DDC	6	1000	178.0	8.4	3.2	3.2	1.4	4.0	8.0	Q3
LMP8640HVMKE-F/NOPB	SOT	DDC	6	250	178.0	8.4	3.2	3.2	1.4	4.0	8.0	Q3
LMP8640HVMKE-H/NOPB	SOT	DDC	6	250	178.0	8.4	3.2	3.2	1.4	4.0	8.0	Q3
LMP8640HVMKE-T/NOPB	SOT	DDC	6	250	178.0	8.4	3.2	3.2	1.4	4.0	8.0	Q3
LMP8640HVMKX-F/NOPB	SOT	DDC	6	3000	178.0	8.4	3.2	3.2	1.4	4.0	8.0	Q3
LMP8640HVMKX-H/NOPB	SOT	DDC	6	3000	178.0	8.4	3.2	3.2	1.4	4.0	8.0	Q3
LMP8640HVMKX-T/NOPB	SOT	DDC	6	3000	178.0	8.4	3.2	3.2	1.4	4.0	8.0	Q3
LMP8640MK-F/NOPB	SOT	DDC	6	1000	178.0	8.4	3.2	3.2	1.4	4.0	8.0	Q3
LMP8640MK-H/NOPB	SOT	DDC	6	1000	178.0	8.4	3.2	3.2	1.4	4.0	8.0	Q3
LMP8640MK-T/NOPB	SOT	DDC	6	1000	178.0	8.4	3.2	3.2	1.4	4.0	8.0	Q3
LMP8640MKE-F/NOPB	SOT	DDC	6	250	178.0	8.4	3.2	3.2	1.4	4.0	8.0	Q3
LMP8640MKE-H/NOPB	SOT	DDC	6	250	178.0	8.4	3.2	3.2	1.4	4.0	8.0	Q3
LMP8640MKE-T/NOPB	SOT	DDC	6	250	178.0	8.4	3.2	3.2	1.4	4.0	8.0	Q3
LMP8640MKX-F/NOPB	SOT	DDC	6	3000	178.0	8.4	3.2	3.2	1.4	4.0	8.0	Q3
LMP8640MKX-H/NOPB	SOT	DDC	6	3000	178.0	8.4	3.2	3.2	1.4	4.0	8.0	Q3

Device	Package Type	Package Drawing	Pins	SPQ	Reel Diameter (mm)	Reel Width W1 (mm)	A0 (mm)	B0 (mm)	K0 (mm)	P1 (mm)	W (mm)	Pin1 Quadrant
LMP8640MKX-T/NOPB	SOT	DDC	6	3000	178.0	8.4	3.2	3.2	1.4	4.0	8.0	Q3

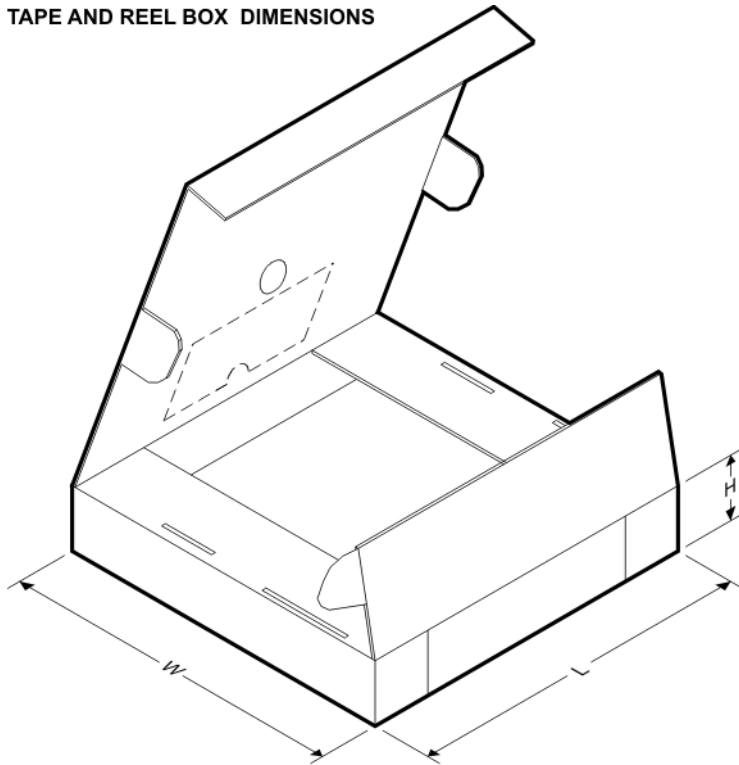
TAPE AND REEL BOX DIMENSIONS

*All dimensions are nominal

Device	Package Type	Package Drawing	Pins	SPQ	Length (mm)	Width (mm)	Height (mm)
LMP8640HVMK-F/NOPB	SOT	DDC	6	1000	210.0	185.0	35.0
LMP8640HVMK-H/NOPB	SOT	DDC	6	1000	210.0	185.0	35.0
LMP8640HVMK-T/NOPB	SOT	DDC	6	1000	210.0	185.0	35.0
LMP8640HVMKE-F/NOPB	SOT	DDC	6	250	210.0	185.0	35.0
LMP8640HVMKE-H/NOPB	SOT	DDC	6	250	210.0	185.0	35.0
LMP8640HVMKE-T/NOPB	SOT	DDC	6	250	210.0	185.0	35.0
LMP8640HVMKX-F/NOPB	SOT	DDC	6	3000	210.0	185.0	35.0
LMP8640HVMKX-H/NOPB	SOT	DDC	6	3000	210.0	185.0	35.0
LMP8640HVMKX-T/NOPB	SOT	DDC	6	3000	210.0	185.0	35.0
LMP8640MK-F/NOPB	SOT	DDC	6	1000	210.0	185.0	35.0
LMP8640MK-H/NOPB	SOT	DDC	6	1000	210.0	185.0	35.0
LMP8640MK-T/NOPB	SOT	DDC	6	1000	210.0	185.0	35.0
LMP8640MKE-F/NOPB	SOT	DDC	6	250	210.0	185.0	35.0
LMP8640MKE-H/NOPB	SOT	DDC	6	250	210.0	185.0	35.0
LMP8640MKE-T/NOPB	SOT	DDC	6	250	210.0	185.0	35.0
LMP8640MKX-F/NOPB	SOT	DDC	6	3000	210.0	185.0	35.0

Device	Package Type	Package Drawing	Pins	SPQ	Length (mm)	Width (mm)	Height (mm)
LMP8640MKX-H/NOPB	SOT	DDC	6	3000	210.0	185.0	35.0
LMP8640MKX-T/NOPB	SOT	DDC	6	3000	210.0	185.0	35.0

DDC (R-PDSO-G6)

PLASTIC SMALL-OUTLINE

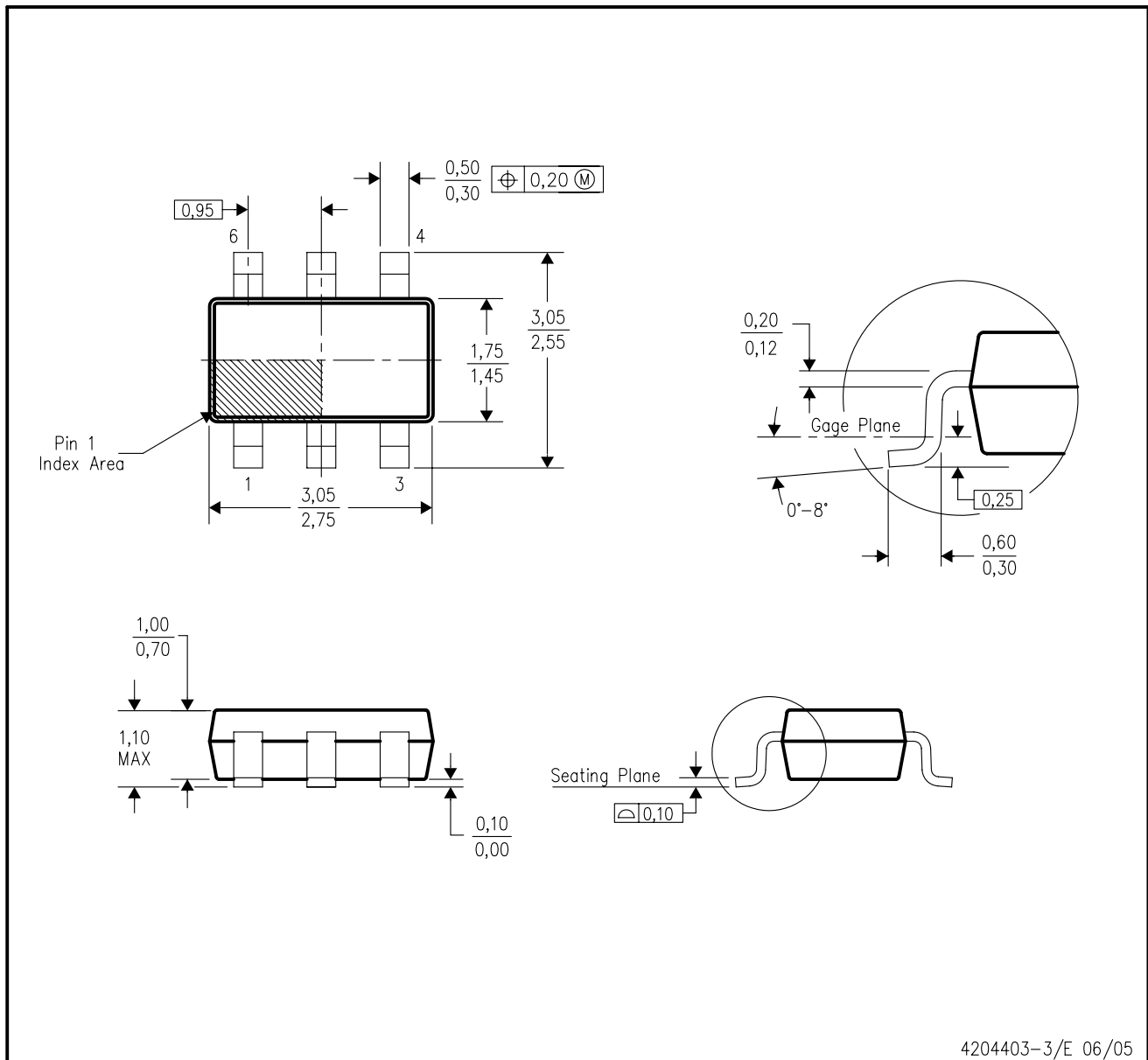

- NOTES:
- All linear dimensions are in millimeters.
 - This drawing is subject to change without notice.
 - Body dimensions do not include mold flash or protrusion.
 - Falls within JEDEC MO-193 variation AA (6 pin).

IMPORTANT NOTICE

Texas Instruments Incorporated and its subsidiaries (TI) reserve the right to make corrections, enhancements, improvements and other changes to its semiconductor products and services per JESD46, latest issue, and to discontinue any product or service per JESD48, latest issue. Buyers should obtain the latest relevant information before placing orders and should verify that such information is current and complete. All semiconductor products (also referred to herein as "components") are sold subject to TI's terms and conditions of sale supplied at the time of order acknowledgment.

TI warrants performance of its components to the specifications applicable at the time of sale, in accordance with the warranty in TI's terms and conditions of sale of semiconductor products. Testing and other quality control techniques are used to the extent TI deems necessary to support this warranty. Except where mandated by applicable law, testing of all parameters of each component is not necessarily performed.

TI assumes no liability for applications assistance or the design of Buyers' products. Buyers are responsible for their products and applications using TI components. To minimize the risks associated with Buyers' products and applications, Buyers should provide adequate design and operating safeguards.

TI does not warrant or represent that any license, either express or implied, is granted under any patent right, copyright, mask work right, or other intellectual property right relating to any combination, machine, or process in which TI components or services are used. Information published by TI regarding third-party products or services does not constitute a license to use such products or services or a warranty or endorsement thereof. Use of such information may require a license from a third party under the patents or other intellectual property of the third party, or a license from TI under the patents or other intellectual property of TI.

Reproduction of significant portions of TI information in TI data books or data sheets is permissible only if reproduction is without alteration and is accompanied by all associated warranties, conditions, limitations, and notices. TI is not responsible or liable for such altered documentation. Information of third parties may be subject to additional restrictions.

Resale of TI components or services with statements different from or beyond the parameters stated by TI for that component or service voids all express and any implied warranties for the associated TI component or service and is an unfair and deceptive business practice. TI is not responsible or liable for any such statements.

Buyer acknowledges and agrees that it is solely responsible for compliance with all legal, regulatory and safety-related requirements concerning its products, and any use of TI components in its applications, notwithstanding any applications-related information or support that may be provided by TI. Buyer represents and agrees that it has all the necessary expertise to create and implement safeguards which anticipate dangerous consequences of failures, monitor failures and their consequences, lessen the likelihood of failures that might cause harm and take appropriate remedial actions. Buyer will fully indemnify TI and its representatives against any damages arising out of the use of any TI components in safety-critical applications.

In some cases, TI components may be promoted specifically to facilitate safety-related applications. With such components, TI's goal is to help enable customers to design and create their own end-product solutions that meet applicable functional safety standards and requirements. Nonetheless, such components are subject to these terms.

No TI components are authorized for use in FDA Class III (or similar life-critical medical equipment) unless authorized officers of the parties have executed a special agreement specifically governing such use.

Only those TI components which TI has specifically designated as military grade or "enhanced plastic" are designed and intended for use in military/aerospace applications or environments. Buyer acknowledges and agrees that any military or aerospace use of TI components which have **not** been so designated is solely at the Buyer's risk, and that Buyer is solely responsible for compliance with all legal and regulatory requirements in connection with such use.

TI has specifically designated certain components as meeting ISO/TS16949 requirements, mainly for automotive use. In any case of use of non-designated products, TI will not be responsible for any failure to meet ISO/TS16949.

Products

Audio	www.ti.com/audio
Amplifiers	amplifier.ti.com
Data Converters	dataconverter.ti.com
DLP® Products	www.dlp.com
DSP	dsp.ti.com
Clocks and Timers	www.ti.com/clocks
Interface	interface.ti.com
Logic	logic.ti.com
Power Mgmt	power.ti.com
Microcontrollers	microcontroller.ti.com
RFID	www.ti-rfid.com
OMAP Applications Processors	www.ti.com/omap
Wireless Connectivity	www.ti.com/wirelessconnectivity

Applications

Automotive and Transportation	www.ti.com/automotive
Communications and Telecom	www.ti.com/communications
Computers and Peripherals	www.ti.com/computers
Consumer Electronics	www.ti.com/consumer-apps
Energy and Lighting	www.ti.com/energy
Industrial	www.ti.com/industrial
Medical	www.ti.com/medical
Security	www.ti.com/security
Space, Avionics and Defense	www.ti.com/space-avionics-defense
Video and Imaging	www.ti.com/video

TI E2E Community

e2e.ti.com